

Internal Diagram

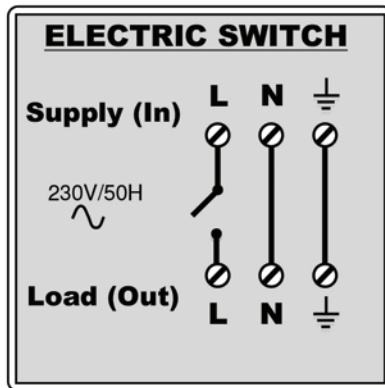

PLEASE NOTE: If the appliance/load this needs to be retained. The Electric Switch has a fused spur then should be wired in line with any existing fused spur.

